

STEERING

CONTENTS

SECTION 6A	POWER STEERING SYSTEM
SECTION 6B	POWER STEERING PUMP
SECTION 6C	POWER STEERING GEAR
SECTION 6E	STEERING WHEEL AND COLUMN

SECTION 6A

POWER STEERING SYSTEM

TABLE OF CONTENTS

<p>Specifications 6A-1</p> <p style="padding-left: 20px;">Fastener Tightening Specifications 6A-1</p> <p>Special Tools 6A-1</p> <p style="padding-left: 20px;">Special Tools Table 6A-1</p> <p>Diagnosis 6A-2</p> <p style="padding-left: 20px;">Power Steering System Pressure Test 6A-2</p> <p style="padding-left: 20px;">Power Steering System Leak Test 6A-2</p> <p>Maintenance and Repair 6A-3</p>	<p>On-Vehicle Service 6A-3</p> <p style="padding-left: 20px;">Bleeding the Power Steering System 6A-3</p> <p style="padding-left: 20px;">Checking and Adding Fluid 6A-3</p> <p style="padding-left: 20px;">Fluid Reservoir 6A-4</p> <p style="padding-left: 20px;">Hoses and Pipes 6A-5</p> <p>General Description and System</p> <p style="padding-left: 20px;">Operation 6A-12</p> <p style="padding-left: 20px;">Power Steering System 6A-12</p>
--	---

SPECIFICATIONS

FASTENER TIGHTENING SPECIFICATIONS

Application	N•m	Lb•Ft	Lb•In
Power Steering Pump Pressure Line Fitting	27	20	-
Return Line Clip Screws	3	-	27
Steering Gear Inlet and Outlet Pipe Fittings	27	20	-

SPECIAL TOOLS

SPECIAL TOOLS TABLE

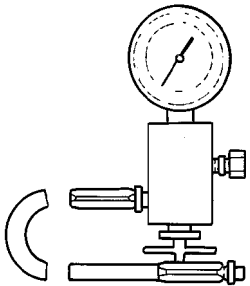
 <p style="font-size: small; margin-top: 5px;">A105A009</p>	<p>KM-354-B Pressure Test Gauge Kit</p>
--	--

DIAGNOSIS

POWER STEERING SYSTEM PRESSURE TEST

Tools Required

KM-354-B Pressure Test Gauge Kit

Check the fluid pressure as follows to determine whether the trouble is in the pump or the gear unit.

Test Procedure

1. Check the power steering fluid level and the power steering pump belt tension. Refer to „Checking and Adding Fluid” in this section and *Section 6B, Power Steering Pump*.
2. Disconnect the high pressure line at the pump. Use a small container to catch any fluid.
3. Connect the hose of the pressure test gauge kit KM-354-B to the power steering pressure hose from the power steering pump.
4. Place the gear selector lever in PARK (automatic transaxle equipped vehicles) or NEUTRAL (manual transaxle equipped vehicles). Set the parking brake.
5. Open the gauge valve fully.
6. Start the engine and let it idle.
7. Turn the steering wheel from lock to lock several times to warm the fluid to operating temperature.
8. Increase the engine speed to 1,500 rpm.

Notice: The power steering pump could be damaged if the valve is fully closed for more than 5 seconds.

9. Close the gauge valve fully, and read the pressure. The pump pressure with the valve closed should be between 8,330 kPa to 8,820 kPa (1,208 psi to 1,279 psi).
With electronic variable orifice, the pressure should be between 8,500 kPa to 8,960 kPa (1,233 psi to 1,299 psi)
10. Immediately open the gauge valve fully.
11. Turn the steering wheel all the way to the left and the right. If the pressure is within the specified limits, the problem is not in the pump. Check the power steering gear for leaks.

POWER STEERING SYSTEM LEAK TEST

General Procedure

Inspect the following:

- The fluid reservoir for overflow.
- Fluid for aeration and overflow.
- The hoses for loose connections.
- The torsion bar, stub shaft and adjuster seals for leaks.
- The component sealing surfaces for damage.

Important: Verify the exact point of the leak. The point from which the fluid is dripping is not necessarily the point at which the system is leaking. When service is required, clean the leak area upon disassembly, replace the leaking seal, check the component sealing surfaces for damage and reset the torque bolt to specifications, where required.

External Leak Check

The purpose of this procedure is to pinpoint the location of the leak. In some cases, the leak can be easily located, but seepage type leaks may be harder to find. To locate seepage leaks, use the following method:

1. With the engine off, wipe dry the complete power steering system.
 2. Check the power steering fluid level in the pump's reservoir. Adjust the fluid level as necessary. Refer to „Checking and Adding Fluid” in this section.
- Notice:** Do not hold the steering wheel at a stop for any length of time as this can damage the power steering pump.
3. Start the engine. Turn the steering wheel counterclockwise and clockwise from stop to stop several times.
 4. Find the exact area of the leak and repair it.

MAINTENANCE AND REPAIR

ON-VEHICLE SERVICE

BLEEDING THE POWER STEERING SYSTEM

If the power steering hydraulic system has been serviced, an accurate fluid level reading cannot be obtained until the air is bled from the system. Follow these steps to bleed the air from the system.

1. Turn the wheels all the way to the left and add the power steering fluid to the MIN mark on the fluid level indicator.

Notice: When adding fluid or making a complete fluid change, always use DEXRON[®] II or III power steering fluid. Failure to use the proper fluid will cause hose and seal damage and fluid leaks.

2. Start the engine. With the engine running at fast idle, recheck the fluid level. If necessary, add fluid to bring the level up to the MIN mark.
3. Bleed the system by turning the wheels from side to side without reaching the stop at either end. Keep the fluid level at the MIN mark. The air must be eliminated from the fluid before normal steering action can be obtained.
4. Return the wheels to the center position. Continue running the engine for 2 to 3 minutes.
5. Road test the car to be sure the steering functions normally and is free from noise.
6. Recheck the fluid level as described in steps 1 and 2. Make sure the fluid level is at the MAX mark after the system has stabilized at its normal operating temperature. Add fluid as needed.

CHECKING AND ADDING FLUID

Notice: When adding fluid or making a complete fluid change, always use DEXRON[®] II or III power steering fluid. Failure to use the proper fluid will cause hose and seal damage and fluid leaks.

1. The power steering fluid level is indicated either by marks on a see through fluid reservoir or by marks on a fluid level indicator on the fluid reservoir cap.
2. If the fluid is warmed up to 66°C (150°F), the fluid level should be between the MAX and MIN marks. Add fluid as needed.
3. If the fluid is cool, 21°C (70°F), the fluid level should be at the MIN mark. Add fluid as needed.

FLUID RESERVOIR

Removal Procedure

1. Siphon the power steering fluid from the fluid reservoir.
2. Loosen the hose clamps and remove both hoses from the fluid reservoir.

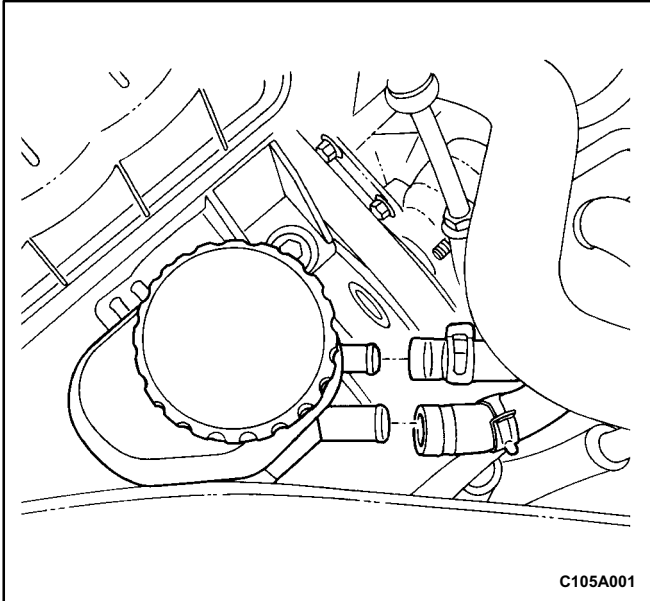

3. Remove the fluid reservoir by sliding it off the fluid reservoir bracket.

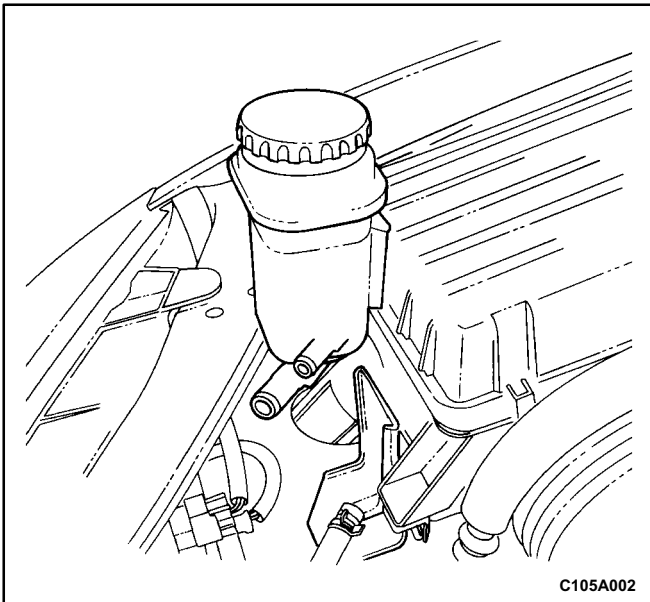

Installation Procedure

1. Attach the fluid reservoir to the fluid reservoir bracket.

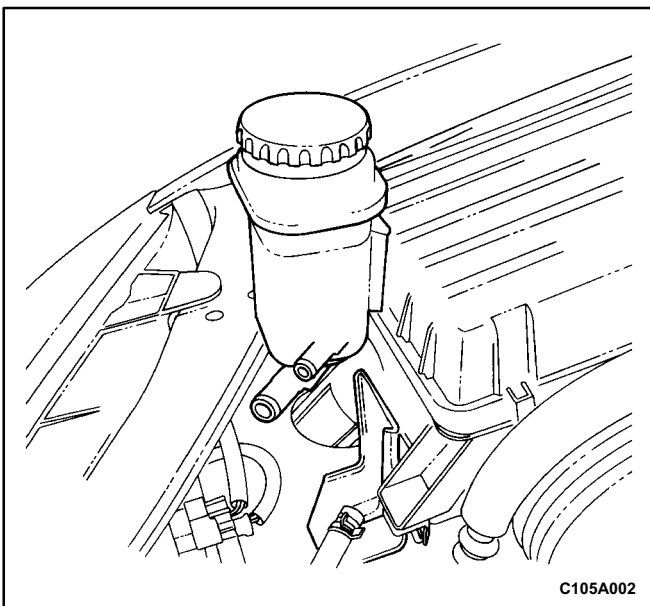

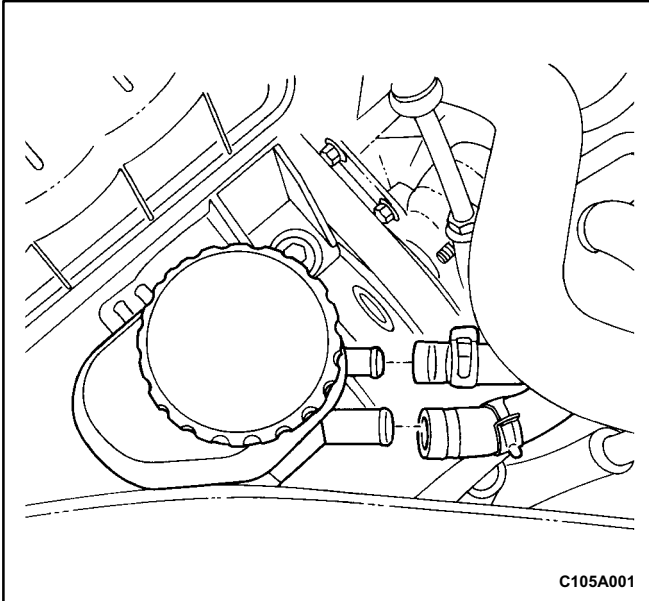

C105A001

2. Connect both hoses to the fluid reservoir and secure the hose clamps.

Notice: When adding fluid or making a complete change, always use DEXRON® II or III power steering fluid. Failure to use the proper fluid will cause hose and seal damage and fluid leaks.

3. Fill the fluid reservoir with power steering fluid.
4. Inspect for leaks. If there are leaks, correct the cause of the leaks and bleed the system. Refer to „Bleeding the Power Steering System” in this section.

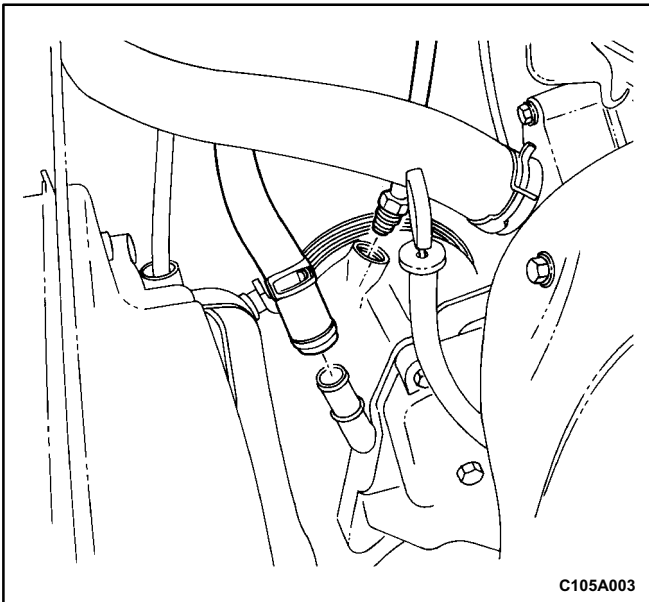

C105A003

HOSES AND PIPES

Power Steering Pump Hoses and Pipes (Left-Hand Drive Shown, Right-Hand Drive Similar)

Removal Procedure

1. Siphon the power steering fluid from the fluid reservoir.
2. Disconnect the pressure line pipe and the supply line hose from the inlet and outlet connections on the power steering pump.

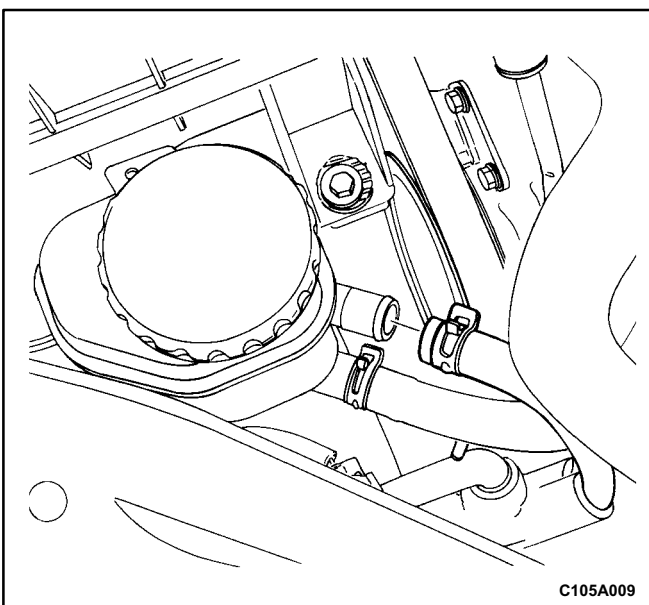

C105A009

3. Disconnect the return line from the fluid reservoir.

6A - 6 POWER STEERING SYSTEM

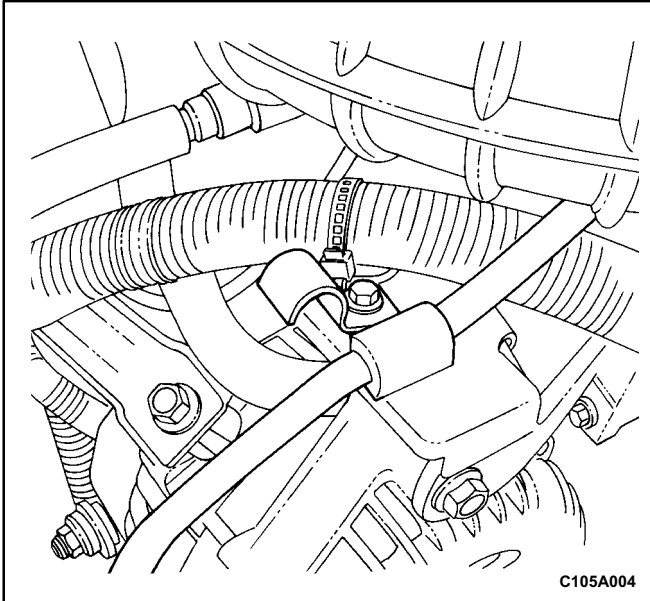

4. Loosen the retaining clip located above the alternator and position it away from the pressure line.

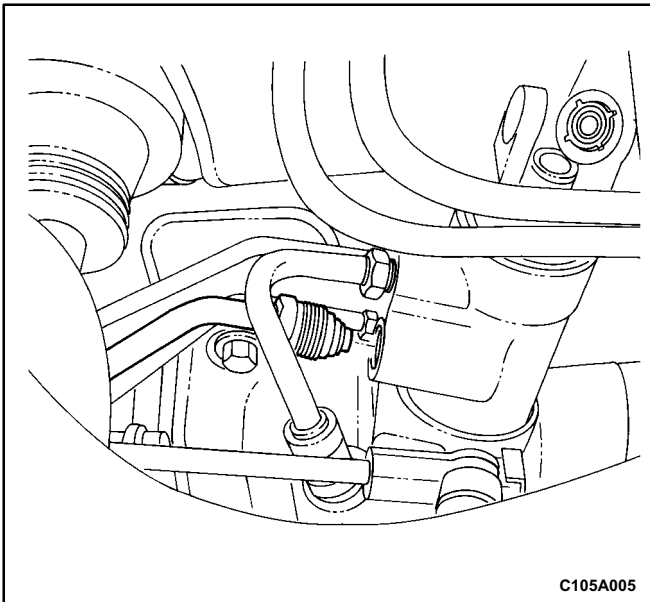

5. Raise and suitably support the vehicle.
6. Disconnect the pressure line from the power steering gear inlet.

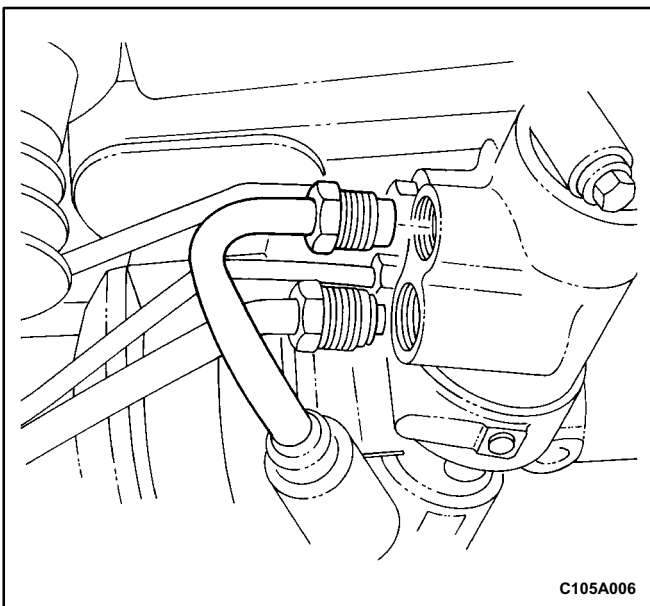

7. Disconnect the return line outlet pipe from the power steering gear.

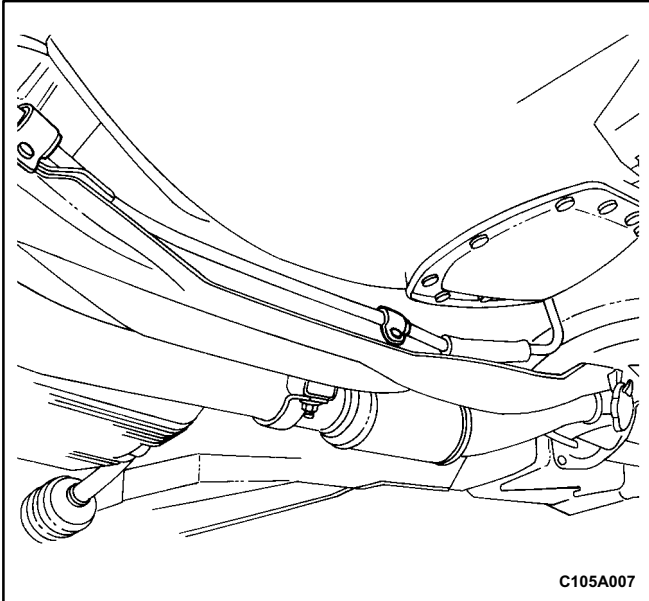

8. Remove the return line from the clips on the frame rail.

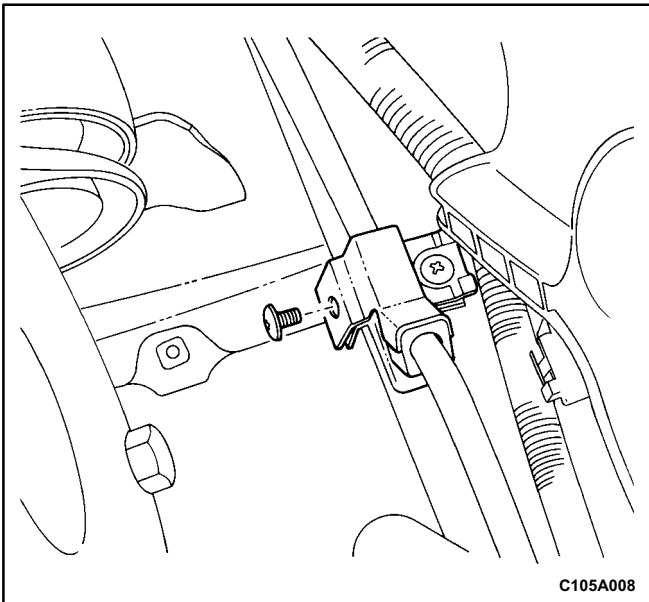

9. Remove the screw from each of the two clips on the radiator support rail.
10. Remove the two clips from the radiator support rail.
11. Remove the return line from the vehicle.
12. Lower the vehicle.
13. Remove the pressure line from the vehicle.

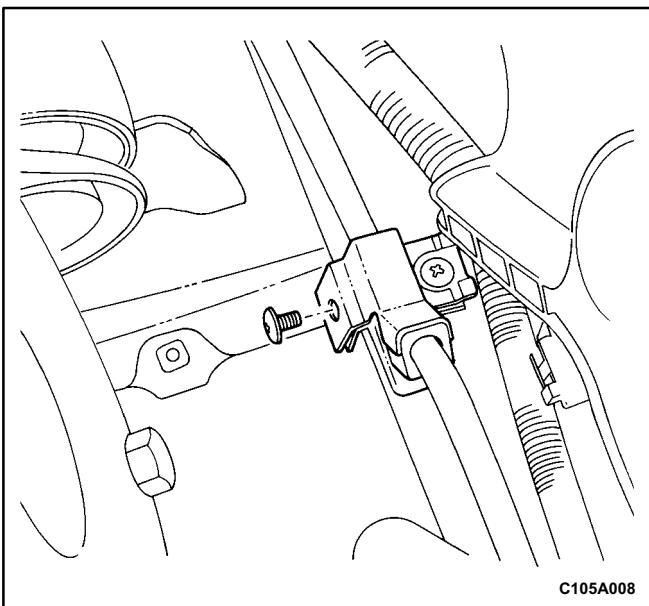

Installation Procedure

1. Route the pressure line from the power steering pump to the power steering gear.
2. Raise and suitably support the vehicle.
3. Route the return line from the fluid reservoir to the power steering gear.
4. Install the two clips on the radiator support rail.
5. Install the screw into each of the two clips.

Tighten

Tighten the return line clip screws to 3 N•m (27 lb•in).

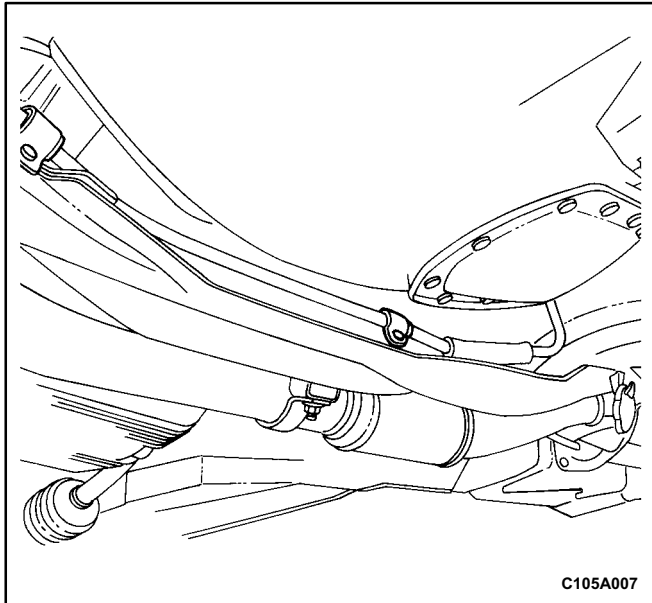

6. Install the return line into the clips on the frame rail.

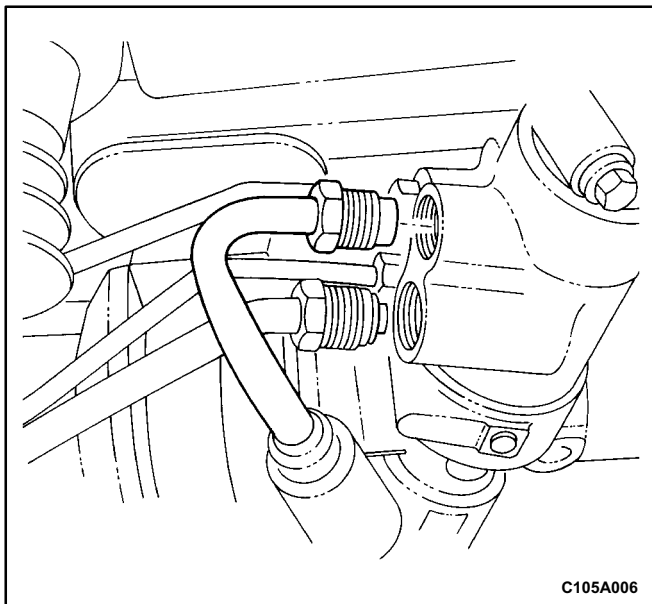

7. Connect the return line to the power steering gear outlet.

Tighten

Tighten the return line fitting to 27 N•m (20 lb•ft).

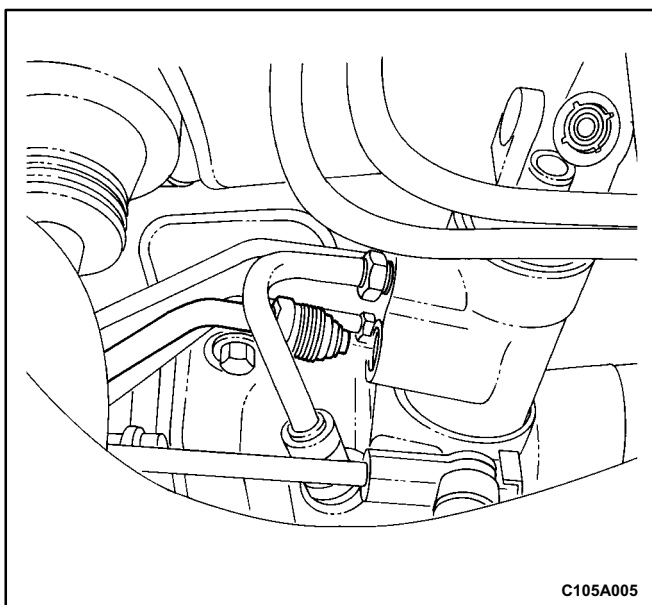

8. Connect the pressure line to the power steering gear inlet.

Tighten

Tighten the pressure line fitting to 27 N•m (20 lb•ft).

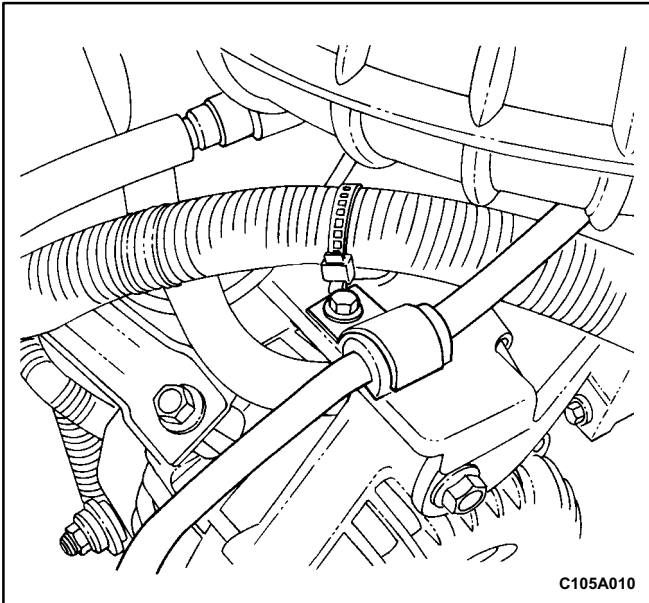

9. Lower the vehicle.
10. Secure the pressure line with the retaining clip located above the alternator.

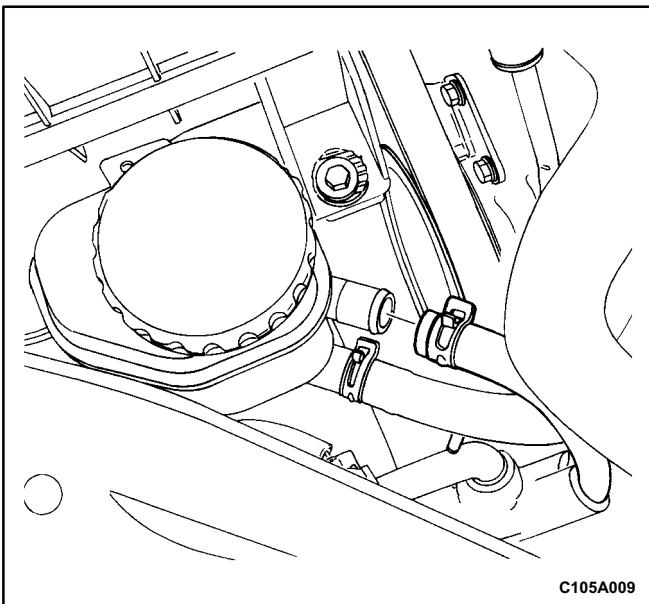

11. Connect the return line to the fluid reservoir.

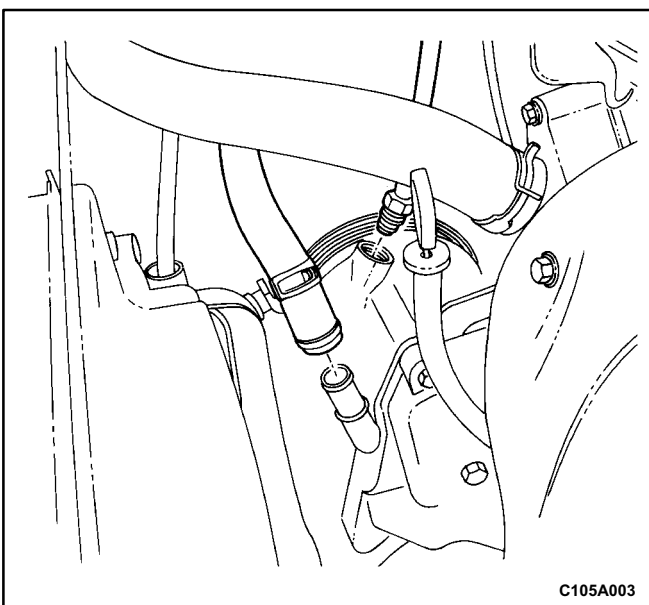

12. Connect the pressure line pipe and the supply line hose to the outlet and inlet connections on the power steering pump.

Tighten

Tighten the pressure line fitting to 27 N•m (20 lb•ft).

Notice: When adding fluid or making a complete change, always use DEXRON® II or III power steering fluid. Failure to use the proper fluid will cause hose and seal damage and fluid leaks.

13. Fill the fluid reservoir with power steering fluid.
14. Inspect for leaks. If there are leaks, correct the cause of the leaks and bleed the system. Refer to „Bleeding the Power Steering System” in this section.

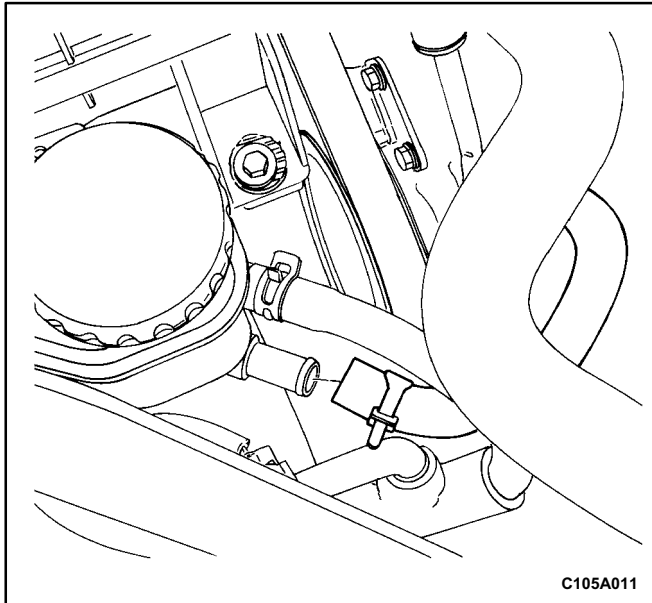

Power Steering Fluid Supply Hose

Removal Procedure

1. Siphon the power steering fluid from the fluid reservoir.
2. Disconnect the fluid supply hose at the fluid reservoir lower connection.

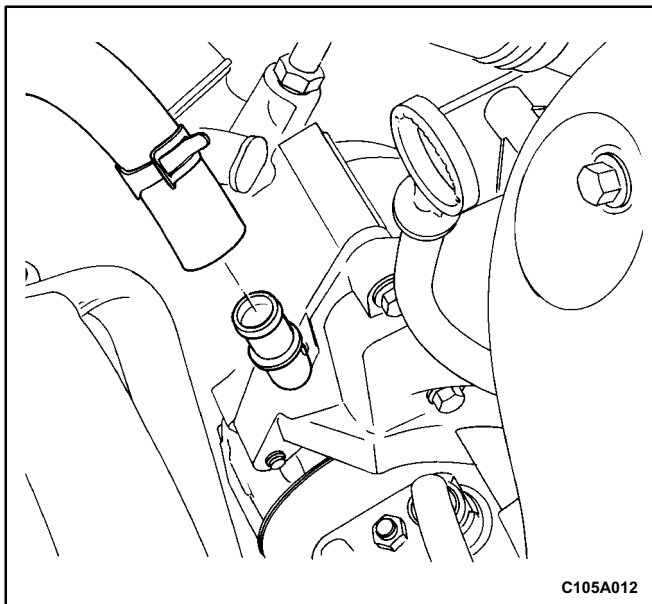

3. Disconnect the fluid supply hose from the power steering pump inlet. Use a rag to avoid any spillage.
4. Remove the power steering fluid supply hose.

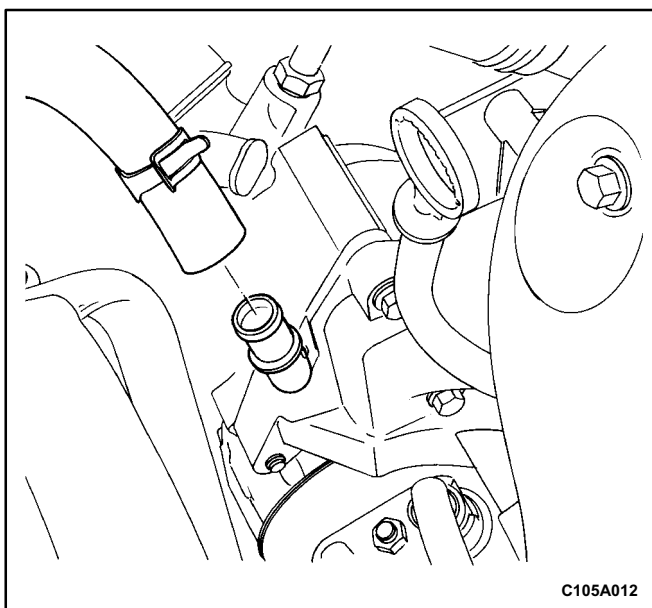

Installation Procedure

1. Install the power steering fluid supply hose.
2. Connect the fluid supply hose to the power steering pump inlet.

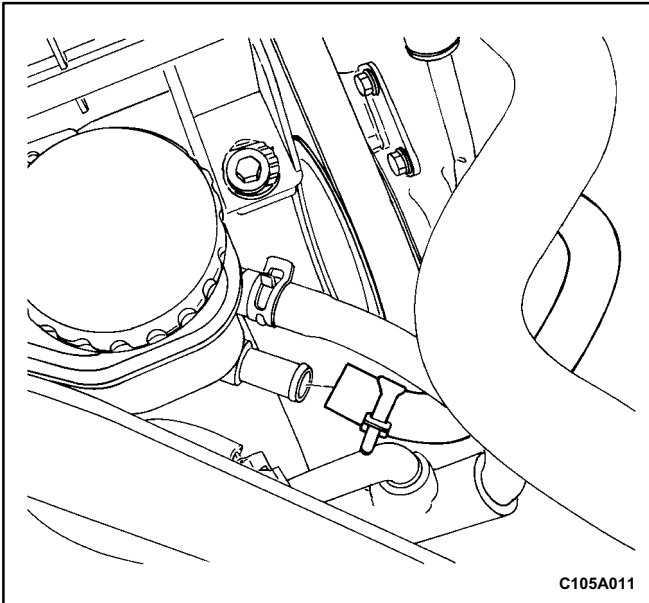

3. Connect the fluid supply hose to the fluid reservoir lower connection.

Notice: When adding fluid or making a complete change, always use DEXRON® II or III power steering fluid. Failure to use the proper fluid will cause hose and seal damage and fluid leaks.

4. Fill the fluid reservoir with power steering fluid.
5. Inspect for leaks. If there are leaks, correct the cause of the leaks and bleed the system. Refer to „Bleeding the Power Steering System” in this section.

GENERAL DESCRIPTION AND SYSTEM OPERATION

POWER STEERING SYSTEM

General Description

The power steering system consists of three components: the power steering pump, the power steering fluid reservoir and the the power steering rack and pinion gear. The power steering pump is a vane type pump providing hydraulic pressure for the system

and is powered by the engine. It draws on the power steering fluid reservoir, which in turn is connected to the power steering gear. A pressure relief valve inside the flow control valve limits the pump pressure. The power steering rack and pinion gear has a rotary control valve which directs hydraulic fluid coming from the power steering pump to one side or the other side of the rack piston. The integral rack piston is attached to the rack. The rack piston converts hydraulic pressure to a linear force which moves the rack to the left or the right. The force is then transmitted through the inner and the outer tie rods to the steering knuckles, which turn the wheels.